

HardieTrim® NT3® **H7L5**

4/4 & 5/4 Boards with Back Grooves



EFFECTIVE SEPTEMBER 2013

Visit www.jameshardie.com for the most recent version.

INSTALLATION REQUIREMENTS - PRIMED & COLORPLUS® PRODUCTS

IMPORTANT: FAILURE TO INSTALL AND FINISH THIS PRODUCT IN ACCORDANCE WITH APPLICABLE BUILDING CODES AND JAMES HARDIE WRITTEN APPLICATION INSTRUCTIONS MAY LEAD TO PERSONAL INJURY, AFFECT SYSTEM PERFORMANCE, VIOLATE LOCAL BUILDING CODES, AND VOID THE PRODUCT ONLY WARRANTY. BEFORE INSTALLATION, CONFIRM THAT YOU ARE USING THE CORRECT HARDIEZONE INSTRUCTIONS.

TO DETERMINE WHICH HARDIEZONE APPLIES TO YOUR LOCATION, VISIT WWW.HARDIEZONE.COM OR CALL 1-866-942-7343 (866 9HARDIE)

STORAGE & HANDLING:

Store flat and keep dry and covered prior to installation. Installing siding wet or saturated may result in shrinkage at butt joints. Carry planks on edge. Protect edges and corners from breakage. James Hardie is not responsible for damage caused by improper storage and handling of the product.



CUTTING INSTRUCTIONS

OUTDOORS

- Position cutting station so that wind will blow dust away from user and others in working area.
- Use one of the following methods:
 - Better:
 - Dust reducing circular saw equipped with a HardieBlade® saw blade and HEPA vacuum extraction
 - Good:
 - Dust reducing circular saw with a HardieBlade saw blade (only use for low to moderate cutting)

INDOORS

- NEVER use a power saw indoors
- NEVER use a circular saw blade that does not carry the HardieBlade saw blade trademark
- NEVER dry sweep – Use wet suppression or HEPA Vacuum
- Important Note: For maximum protection (lowest respirable dust production), James Hardie recommends always using “Best”-level cutting methods where feasible.

NIOSH-approved respirators can be used in conjunction with above cutting practices to further reduce dust exposures. Additional exposure information is available at www.jameshardie.com to help you determine the most appropriate cutting method for your job requirements. If concern still exists about exposure levels or you do not comply with the above practices, you should always consult a qualified industrial hygienist or contact James Hardie for further information. SD050905

INSTALLATION

Fastener Requirements

For Corners, Band Boards, Windows, and Door Applications:

HardieTrim NT3 boards with back grooves are installed with HardieTrim™ Flat Tabs (JH sku no. 280154) and HardieTrim™ Corner Tabs (JH sku no. 280155) which provide concealed fastening. Only HardieTrim Flat and Corner Tabs can be used with HardieTrim NT3 boards to create a concealed fastening.

Step 1: Attach HardieTrim Flat Tabs to the back side of the trim using four(4) 18 ga. 1/2" L x 1/4" W narrow crown corrosion resistant staples, equally spaced in one row, positioned no closer than 1/2" from trim edges using a pneumatic staple gun. (Figure 1)

Step 2: For wood frame construction, attach the trim to the building with minimum 2, 6d siding nails fastened through the HardieTrim Flat Tabs (Figures 2 & 3) *. ET&F or equivalent fasteners may be used to attach the HardieTrim Flat Tabs to steel frame construction. (Figures 2 & 3)

Fastener spacing will vary based on application. Refer to fastener table on page 4. Refer to specific sections in these instructions for required fastener spacing by application (window, band board, etc.)

HardieTrim® NT3 boards can also be installed in a more traditional fashion with finish nails. Use minimum 16 ga. 2" galvanized finish nails spaced at 16" o.c. to attach the trim.

For Fascia, Rake, and Frieze board Applications:

For fascia, rake, and frieze board applications, use minimum 16 ga. 2" galvanized finish nails to attach the HardieTrim NT3™ boards. Position finish nails no closer than 1/2" from the edges and no closer than 1" from the ends of the trim. Fasteners may be spaced at a maximum of 16" o.c. Ensure trim is adequately fastened.

Installation of HardieTrim tabs in Coastal Regions:

James Hardie requires that stainless steel staples & fasteners be used when installing HardieTrim Tabs in coastal regions.

Installation of HardieTrim Tabs over Pressure Treated Lumber:

HardieTrim tabs shall not come in direct contact with ACQ or CA preservative-treated wood. Refer to the General Fastening section of this document for further information.

HardieTrim NT3 boards with ColorPlus® Technology: Remove the laminate sheet as soon as possible after attaching the trim to the building.

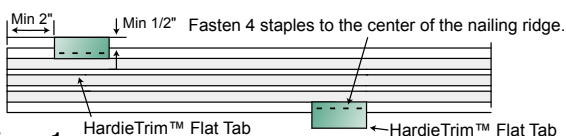

Figure 1

*For additional information on HardieWrap® Weather Barrier, consult James Hardie at 1-866-4Hardie or www.hardiewrap.com

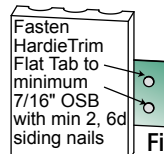

Figure 2

HardieTrim® NT3™ board is a decorative non-load bearing trim product.

GENERAL REQUIREMENTS:

- Wood or steel backing must be provided for attaching HardieTrim® NT3™ boards and the HardieTrim™ Flat Tabs. Additional framing may be required to ensure the HardieTrim™ Flat and Corner Tabs are fastened properly to the structure. Special attention should be paid to the framing when using a sheathing that does not have fastener holding equivalent to OSB or Plywood sheathing.
- A water-resistive barrier is required in accordance with local building code requirements. The water-resistive barrier must be appropriately installed with penetration and junction flashing in accordance with local building code requirements. James Hardie will assume no responsibility for water infiltration. James Hardie does manufacture HardieWrap® Weather Barrier, a non-woven non-perforated housewrap¹, which complies with building code requirements.
- Adjacent finished grade must slope away from the building in accordance with local building codes - typically a minimum of 6" in the first 10'.
- Flashing is required over horizontal protruding and exposed trim
- Do not install James Hardie® products such that they may remain in contact with standing water.
- DO NOT use stain, oil/alkyd base paint, or powder coating on James Hardie® Products.
- DO NOT Install HardieTrim over any lapped siding products.

Figure 3

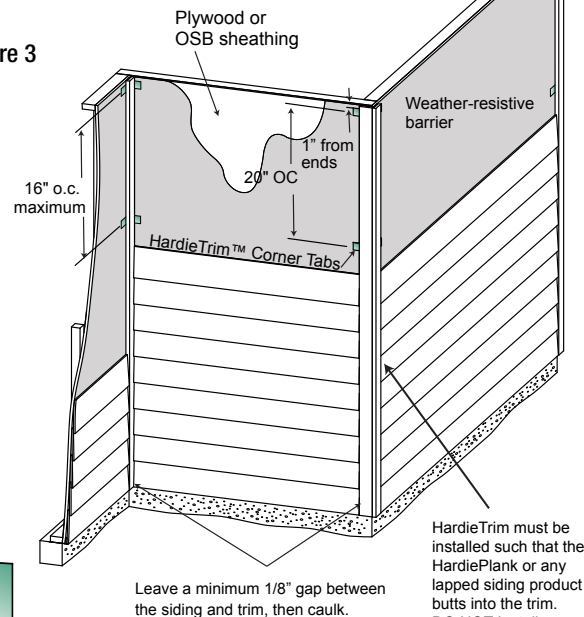

HardieTrim must be installed such that the HardiePlank or any lapped siding product butts into the trim. DO NOT Install HardieTrim over any lapped siding products.

Leave a minimum 1/8" gap between the siding and trim, then caulk.

WARNING: AVOID BREATHING SILICA DUST

James Hardie® products contain respirable crystalline silica, which is known to the State of California to cause cancer and is considered by IARC and NIOSH to be a cause of cancer from some occupational sources. Breathing excessive amounts of respirable silica dust can also cause a disabling and potentially fatal lung disease called silicosis, and has been linked with other diseases. Some studies suggest smoking may increase these risks. During installation or handling: (1) work in outdoor areas with ample ventilation; (2) use fiber cement shears for cutting or, where not feasible, use a HardieBlade® saw blade and dust-reducing circular saw attached to a HEPA vacuum; (3) warn others in the immediate area; (4) wear a properly-fitted, NIOSH-approved dust mask or respirator (e.g. N-95) in accordance with applicable government regulations and manufacturer instructions to further limit respirable silica exposures. During clean-up, use HEPA vacuums or wet cleanup methods - never dry sweep. For further information, refer to our installation instructions and Material Safety Data Sheet available at www.jameshardie.com or by calling 1-800-9HARDIE (1-800-942-7343). FAILURE TO ADHERE TO OUR WARNINGS, MSDS, AND INSTALLATION INSTRUCTIONS MAY LEAD TO SERIOUS PERSONAL INJURY OR DEATH. SD050905

TRIMMING CORNERS

HardieTrim® NT3™ boards with back grooves are installed around corners by pre-building the corner off the wall with the HardieTrim™ Corner Tabs (JH sku no. 280155).

- Attach HardieTrim Corner Tabs to the back side of the trim using eight(8) - 18 ga. 1/2"L x 1/4"W narrow crown corrosion resistant staples using a pneumatic stapler. Ensure the HardieTrim Corner Tabs are fastened tight and straight to the trim boards. (Figure 4)
- For wood frame construction, attach trim to building using min. 6d siding nails fastened through the HardieTrim Corner Tabs attached to minimum 7/16" OSB *. (Figure 5)
- Attach a HardieTrim Corner Tab 1" from each ends and every 20" o.c.
- TIP: Creating a jig for the work station is recommended to ensure corners are fastened securely and straight. (Figure 7)

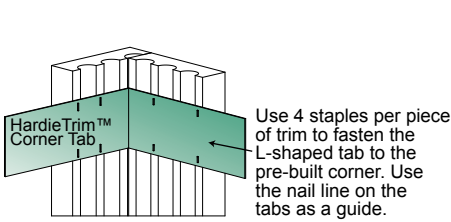

Figure 4

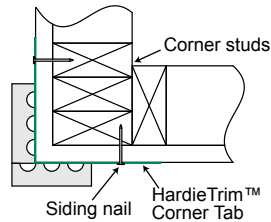

Figure 5

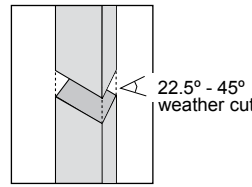

Figure 6

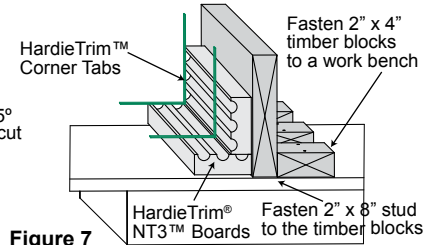

Figure 7

HardieTrim NT3™ boards with back grooves can also be installed directly to the building corners using minimum 16 ga. 2" galvanized finish nails 16" o.c.

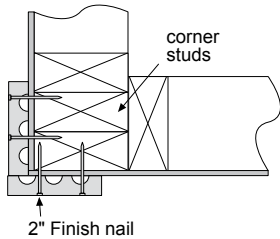

Figure 8

CLEARANCES When installing James Hardie® products, all clearance details need to be followed.

Install siding and trim products in compliance with local building code requirements for clearance between the bottom edge of the siding and the adjacent finished grade.

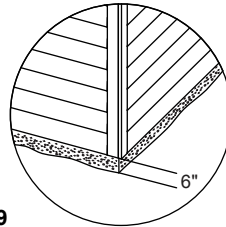

Figure 9

Maintain a minimum 2" clearance between James Hardie® trim products and decks, paths, steps and driveways.

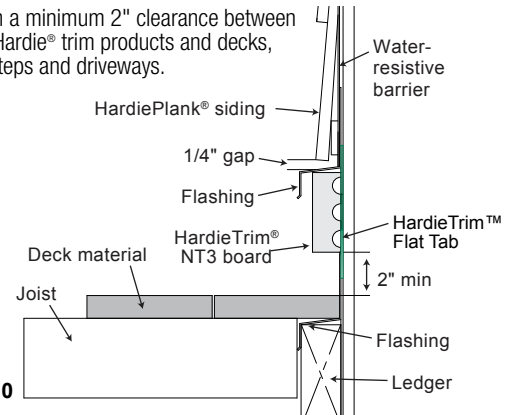

Figure 10

Maintain a 1/4" clearance between the bottom of James Hardie® products and horizontal flashing. Do not caulk gap.

At the juncture of the roof and vertical surfaces, flashing and counterflashing shall be installed per the roofing manufacturer's instructions. Provide a 2" clearance between the roofing and the bottom edge of the trim.

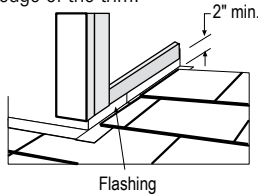

Figure 11

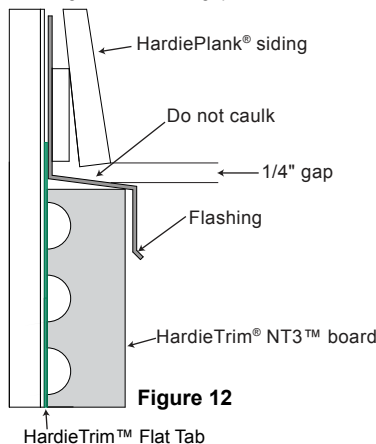

Figure 12

Maintain a minimum 1" gap between gutter end caps and siding & trim.

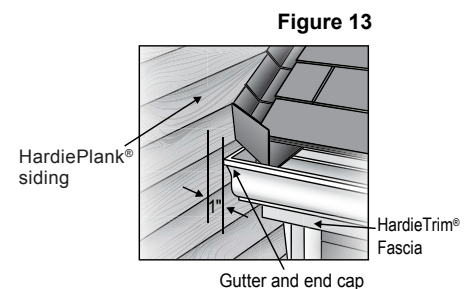

Figure 13

VALLEY FLASHING

The valley flashing must extend a minimum 2" past the HardieTrim® Fascia and 6" to either side. If the valley flashing has been cut flush with the roofing, an additional valley flashing extension must be installed. If rain gutter is present and roof shingles extend 1" past fascia, a valley flashing extension is not required.

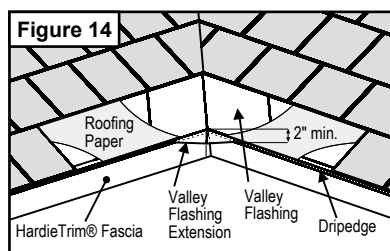

Figure 14

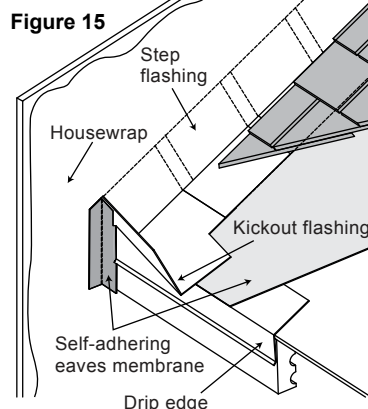

Figure 15

KICKOUT FLASHING

Because of the volume of water that can pour down a sloped roof, one of the most critical flashing details occurs where a roof intersects a sidewall. The roof must be flashed with step flashing. Where the roof terminates, install a kickout to deflect water away from the siding.

It is best to install a self-adhering membrane on the wall before the subs fascia and trim boards are nailed in place, and then come back to install the kickout.

Figure 15, Kickout Flashing To prevent water from dumping behind the siding and the end of the roof intersection, install a "kickout" as required by IRC code R905.2.8.3 : "...flashing shall be a min. of 4" high and 4" wide." James Hardie recommends the kickout be angled between 100° - 110° to maximize water deflection

TRIM APPLICATION FOR WINDOWS, DOORS & OTHER OPENINGS

Trim the opening prior to the installation of the siding (Figure 16).

Place a Flat Tab at the end of each trim board and one tab every 16" OC. Attach the trim boards and Flat Tabs around the opening as shown in Figures 16 and 17. Use 16 ga. galvanized 2" long finish nails to ensure proper fastening if needed.

Figure 16

Side trim pieces go to the top of the window.

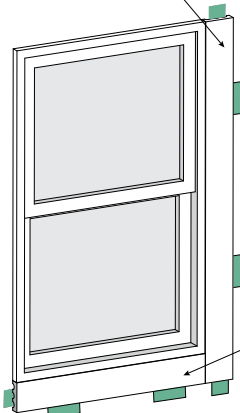

Bottom trim piece is the width of the window.

NOTE: Follow your window/door manufacturers installation instructions.

Figure 17

Header piece spans the window including the side trim pieces.

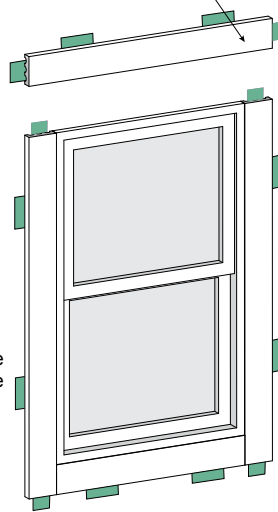

Flashing needs to be tucked under the water resistant barrier and over the Flat Tabs.

Do not caulk between the siding and the flashing.

Water-resistant Barrier 1/4" gap

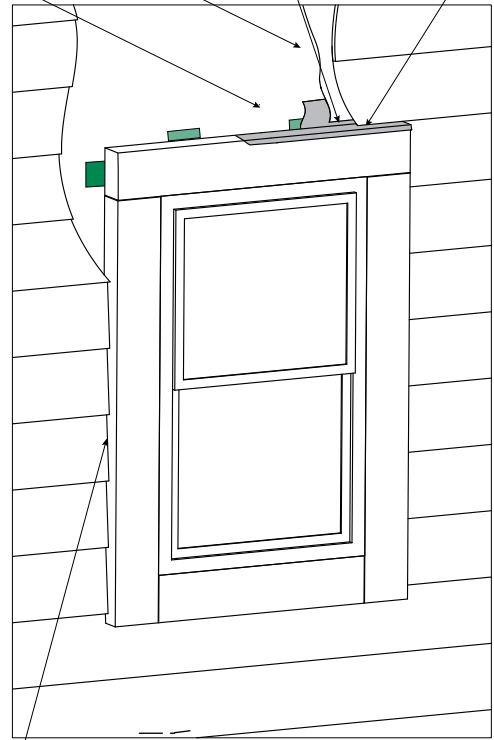

1/8" caulked gap is left between siding and the side trim pieces.

Figure 18

BAND BOARDS, FRIEZE BOARDS, RAKE TRIM & FASCIA

HardieTrim® NT3 boards may also be used as band boards, frieze boards, rake trim or fascia (Figure 19). Use 16 ga. galvanized 2" long finish nails to ensure proper fastening if needed.

Figure 19

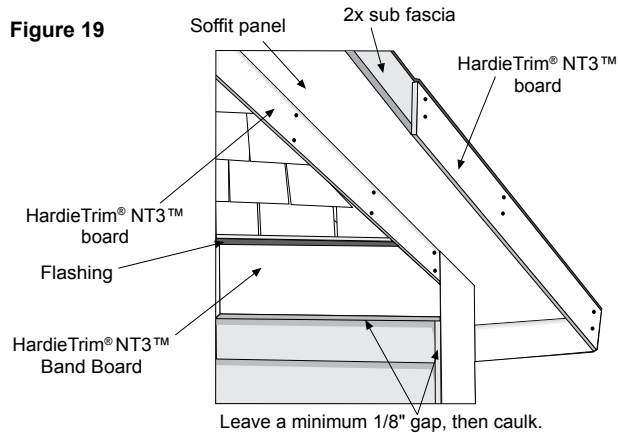

FRIEZE BOARDS

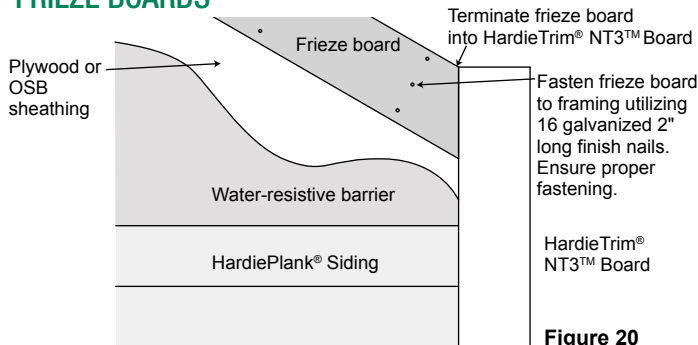
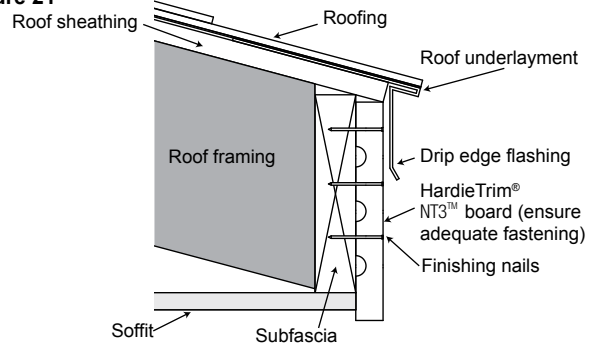

Figure 20

FASCIA & RAKE

For fascia and rake applications, a flashing is required over top of the fascia (Figure 21).

Figure 21



**Figure 22
Birdhouse Detail**

Ensure that all birdhouse trim is adequately fastened to a solid substrate.

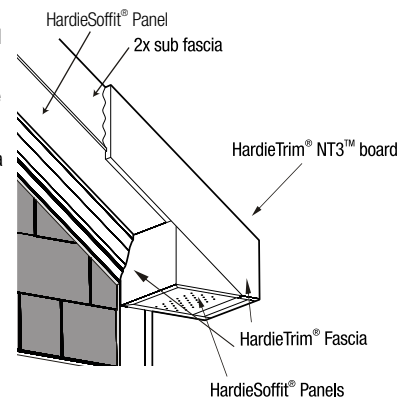

BAND BOARD

A flashing is required over the trim and HardieTrim™ Flat Tabs. (Figure 23) Terminate ends of the Band Board into Trim or Siding or miter cut the edges of the trim at the corners of the building. Place a HardieTrim™ Flat Tab at the end of each trim board and one tab every stud at a maximum of 16" o.c. The HardieTrim™ Flat Tabs should be attached to the trim in an alternating pattern to the top and bottom of the band board (Figure 24, 25). Use 16 ga. galvanized 2" long finish nails to ensure proper fastening if needed.

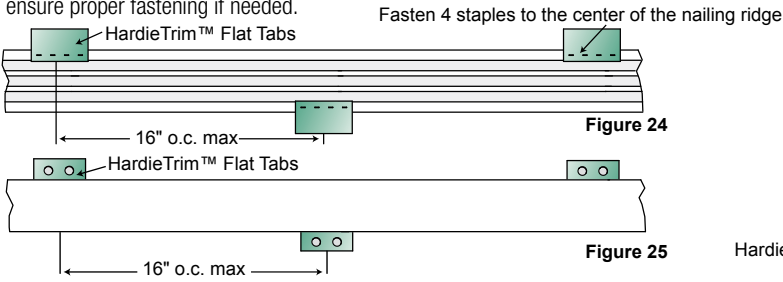
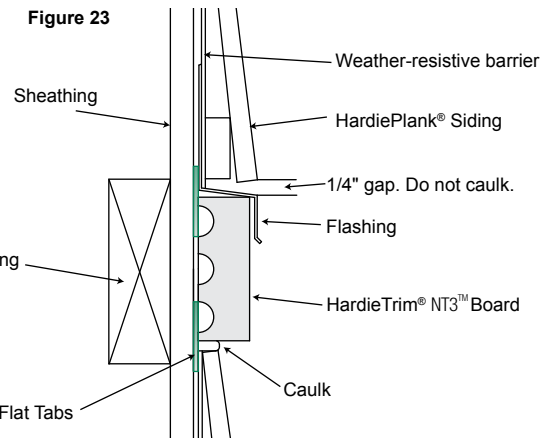

Figure 23



GENERAL FASTENING REQUIREMENTS

Fasteners must be corrosion resistant, galvanized, or stainless steel. Electro-galvanized are acceptable but may exhibit premature corrosion. James Hardie recommends the use of quality, hot-dipped galvanized fasteners. James Hardie is not responsible for the corrosion resistance of fasteners. Stainless steel fasteners are recommended when installing James Hardie® products near the ocean, large bodies of water, or very humid climates.

Manufacturers of ACQ and CA preservative-treated wood recommend spacer materials or other physical barriers to prevent direct contact of ACQ or CA preservative-treated wood and aluminum products. Fasteners used to attach HardieTrim™ Tabs to preservative-treated wood shall be of hot dipped zinc-coated galvanized steel or stainless steel and in accordance to 2009 IRC R317.3 or 2009 IBC 2304.9.5."

- Drive fasteners perpendicular to the trim and framing.
- Do not drive fasteners at an angle.
- For wood framing, under driven fasteners should be hit flush to the HardieTrim™ Flat and Corner Tabs with a hammer (for steel framing, remove and replace nail).
- **Do not use aluminum fasteners, staples, or clipped head nails to attach the product directly to the building.**

Figure 26

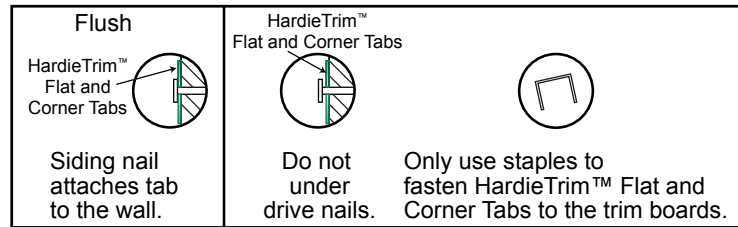

PNEUMATIC FASTENING:

HardieTrim™ NT3™ boards with the back groove can be fastened with a pneumatic tool. All fasteners should be driven flush to the HardieTrim™ Flat and Corner Tabs (Figure 26). A flush mount attachment on the pneumatic tool is recommended. This will help control the depth the fastener is driven. If setting the depth proves difficult, choose a setting that under drives the fastener. (Drive under driven fasteners snug with a smooth faced hammer - Does not apply for installation to steel framing).

FASTENER TABLE

Application	Framing Material Tab is nailed into	Fastener (tab to framing)	Fastener (tab to NT3 trim)	Max Tab Spacing (inches on center)
Flat Tab	Wood Stud (minimum G=0.42)	One 6d corrosion resistant siding nail installed through center of flange into framing	Four 18 ga. X 1/2" long X 1/4" wide corrosion resistant crown staples, equally spaced in one row	16
	Minimum APA rated 7/16" OSB	Two 4d ring shank corrosion resistant siding nails equally spaced installed through flange into framing		
	Minimum 20 gauge steel	One No. 8 X 1" long X 0.323" head diameter screw (corrosion resistant) installed through flange into framing		
Corner Tab	Wood Stud (minimum G=0.42)	On each flange, install one 6d corrosion resistant siding nail through flange into framing	For each piece of trim, install Four 18 ga. X 1/2" long X 1/4" wide corrosion resistant crown staples, equally space in two rows	20
	Minimum APA rated 7/16" OSB	On each flange, install two 4d ring shank corrosion resistant siding nails through flange into framing		
	Minimum 20 gauge steel	On each flange, install one No. 8 X 1" long X 0.323" head diameter screw (corrosion resistant) through flange into framing		

Wind-Borne Debris Region: "Supplemental fasteners may be necessary when installing tabs in a Wind-Borne Debris Region, please call Technical Services 800-942-7343 with any questions."

CUT EDGE TREATMENT

Caulk, paint or prime all field cut edges. James Hardie touch-up kits are required to touch-up ColorPlus products.

CAULKING

For best results use an Elastomeric Joint Sealant complying with ASTM C920 Grade NS, Class 25 or higher or a Latex Joint Sealant complying with ASTM C834. Caulking/Sealant must be applied in accordance with the caulking/sealant manufacturer's written instructions. **Note: OSI Quad as well as some other caulking manufacturers do not allow tooling.**

PAINTING

DO NOT use stain, oil/alkyd base paint, or powder coating on James Hardie® Products. James Hardie products must be painted within 180 days for primed product and 90 days for unprimed. 100% acrylic topcoats are recommended. DO NOT paint when wet. For application rates refer to paint manufacturers specifications. Back-rolling is recommended if the siding is sprayed.

COLORPLUS® TECHNOLOGY CAULKING, TOUCH-UP & LAMINATE

- Care should be taken when handling and cutting James Hardie ColorPlus products. During installation use a wet soft cloth or soft brush to gently wipe off any residue or construction dust left on the product, then rinse with a garden hose.
- Touch up nicks, scrapes and nail heads using the ColorPlus Technology touch-up applicator. Touch-up paint should be used sparingly. If large areas require touch-up, replace the damaged area with new HardieTrim NT3 board with ColorPlus Technology.
- Laminate sheet must be removed immediately after installation of each trim board.
- Terminate non-factory cut edges into trim where possible, and caulk. Color matched caulks are available from your ColorPlus® product dealer.
- Treat all other non-factory cut edges using the ColorPlus Technology edge coat, available from your ColorPlus product dealer.

Note: James Hardie does not warrant the usage of third party touch-up and paints or paints used as a touch-up on James Hardie ColorPlus products.

Problems with appearance or performance arising from use of third party touch-up paints or paints used as touch-up that are not James Hardie touch-up, will not be covered under the James Hardie ColorPlus Limited Finish Warranty.

PAINTING JAMES HARDIE® SIDING AND TRIM PRODUCTS WITH COLORPLUS® TECHNOLOGY

When repainting ColorPlus® products, James Hardie recommends the following regarding surface preparation and topcoat application:

- Ensure the surface is clean, dry, and free of any dust, dirt, or mildew
- Repriming is normally not necessary
- 100% acrylic topcoats are recommended
- DO NOT use stain, oil/alkyd base paint, or powder coating on James Hardie® Products
- Apply finish coat in accordance with paint manufacturers written instructions regarding coverage, application methods, and application temperature
- DO NOT caulk nail heads when using ColorPlus products, refer to the ColorPlus touch-up section

RECOGNITION: HardieTrim boards may be installed as an equal alternative to conventional trim permitted for use in; 2006, 2009, & 2012 International Building Code, Section 1402.1, and the 2006, 2009, & 2012 International Residence Code for One - and Two - Family - Dwellings, Section R703.1.